

Схемы запасных
частей

 **EUROBOOR**
FOR PROFESSIONALS BY PROFESSIONALS

Магнитный сверлильный станок

ECO 55-TA



Зап. части ECO.55-TA

Номер	Артикул	Описание	Рекомендованная розничная цена, у.е.
1	055.1001	Motor unit 220-240 V	545,00
2	050.0106	Screw 4,8x45	1,00
3	050.0059	Protective cover 53 x 35	2,50
4	050.1013	Led screen	16,00
5	050.0060	Screw M3 x 5	По запросу
6	050.0133	End plate	1,62
7	050.0130	End cover	12,00
8	050T.0332	Screw for speed control unit	По запросу
9	050T.0340X	Control unit 2 (110 & 220v)	49,00
10	050.0147	Carbon brush set 220V	9,97
11 -16	050.0371	Carbon brush holder	6,24
17	050.0586	Cable housing	По запросу
18	050T.0002	Control Unit 1 220V	43,00
19	050.0131	Housing	24,50
20	050.0587	Screw pkvz 4,8 x 35	По запросу
21	050T.0278	Field 230V	58,00
22	020.0328	Screw M4 x 70	По запросу
23	050.0261	Baffle	6,56
24	050T.0346	Rubber ring	1,00
25	050T.0180	Armature speed disk	1,16
26	032.0126	Bearing 8x22x7 608	4,00
27	050T.0183	Armature 230V	125,00
28	032.0166	Circlip 472/28/1.2	1,00
29	032.0171	Bearing 6001 12 x 28 x 8	7,00
30	050.0064	Oil bearing 15 x 21 x 3	2,00
31	050.0236/Y	Inner gear plate	48,00
32	040.0161	Needle bearing HK 0810	11,27
33	050.0065	Metal ring diam. 40	2,50
34	050.0176	Circlip 471/11	1,00
35	050.0071	O-ring 82 x 1.8	2,00
36	050.0207	Gasket middle	2,00
37A	050.0251	First gear	25,60
37B	050.0246	Gear shaft	32,14
38	050.0171	Gear 34/40Z	45,44
39	050.0231	Axle 13T	34,61
40	100.4496	Key 5x5x28	1,78
41	020.0156	Screw SSM6x20	По запросу
42	050.0074	Rack - 1.5X39T	17,00
43	050.0076	Circlip diam. 20	1,00
44	050.0463	Gear 1 x 45T	45,00
45	050.0462	Washer 20.5 x 28 x 0.2	1,00
46	030.0009	Bearing 6004DDU	11,45
47	050.0066	Oil bearing 28 x 38 x 7	6,40
48	050.0078	Ring 41.5 x 36.5 x 1.5	1,00
49	050.1014	Gear Switch	15,10
50	050.0081	O-ring	1,50
51	050.0025	Pin	1,00
52	020.0329	Screw M4 x 16	1,00
53	050.0082	Screw holder	1,50
54	050.1005A	Clutch shaft	8,50
55	032.0211	Casing pin 4 x 12	1,00
56	020.0063	Screw M5x20	По запросу

Зап. части ECO.55-TA

Номер	Артикул	Описание	Рекомендованная розничная цена, у.е.
57	020.0289	Coolant hanger	По запросу
58	050.1015	Gear box 230V	115,70
59	050.0068	Bearing 61906DDU	11,00
60	020.0146	Screw M6 x 25	По запросу
61	020.0111	Washer M6 DIN7980	По запросу
62	050.0077	Key 6 x 6 x 12	По запросу
63	050.0461	Spindle drive shaft 34x146	64,00
64-65	020.0086/Z	Rail set Aluminium (L + R) Z-profile	28,60
66	020.0063	Screw M5x20	По запросу
67	020.0101	Panel Screw BKVZM4x8	1,00
68	055.0002	Rear panel plate 230V	По запросу
69 -74	055.0021	Speed control unit 220 Volt	89,00
75	020.0298	Motor cable clamp	По запросу
76	020.0081	End Screw BKVZM6x20	По запросу
77	020.0077	End plate	По запросу
78	050.0063	Bearing	По запросу
79	020.0516	Screw SS M5 x 10	1,00
80	055.0006X	Frame	По запросу
81	020.0046	Motor cable	9,75
82	020.0041	Coupling nut (motor cable) PG9	4,98
83	050.0056	Stepper motor	85,00
84	050.0028	Washer $\Phi 25 \times \Phi 37 \times 3.0$	По запросу
85	040.0086	Bearing 6001DDU	7,00
86	055.0016	Screw M4x5	По запросу
87	050.0042	Worm 1x0.9	40,00
88	055.0008	Bearing 628/7-ZZ	6,70
89	050.0033X	Gear box plate	По запросу
90	020.0229	Screw M4x20	1,52
91 -101	055.0020	Drilling rocker arms	По запросу
102	030.0030X	Arm for capstan	По запросу
103	050.0027	Washer $\Phi 36 \times \Phi 42 \times 0.2$	По запросу
104	055.0017	Bearing 61907	По запросу
105	050.0044	Circlip $\Phi 35$	По запросу
106	050.0041	Turbine - 50x0.9	49,00
107	050.0029	Washer - $\Phi 28.5 \times \Phi 38 \times 2.0$	По запросу
108	050.0045	Circlip $\Phi 28$	По запросу
109A	020.0031	Coupling nut (Main cable) PG11	3,88
109B	020.0036	Main cable complete 220-240V	15,21
110-111	020.0182	Grounding Screw/washer/Nut	По запросу
112-114	020.0037	Cable clamp	По запросу
115	020.0257	Capacitance	По запросу
116	055.0018	PCB box-2	По запросу
117	055.0007	Drive Board	22,00
118	055.0019	PCB box-1	По запросу
119	032T.0019XA	Screw M3X8	По запросу
120	050.0048	Panel washer	По запросу
121	020.0183	Screw	По запросу
122	055T.0049	Front panel plate	По запросу
123	055.0022	Screw M4x12	По запросу
124	100.0152	R/L Switch (push) 1800 W	7,55
125	030E.0091/Y	Motor switch (5-pin) 220-240V	14,42
126	020.0017	Fuse 5x20 F2A	1,83
127	020.0016	Fuse holder	7,52

Зап. части ECO.55-TA

Номер	Артикул	Описание	Рекомендованная розничная цена, у.е.
128	020.0011	Magnet switch	7,87
129	020.0206	LED indicator set	7,29
130	050T.1009	Potentiometer (turn)Knob	14,00
131	055.0024	Washer	По запросу
132	020.0111	Washer M6 DIN7980	По запросу
133	020.0201/2	Sensor	5,50
134	050.1003	Magnet	155,00

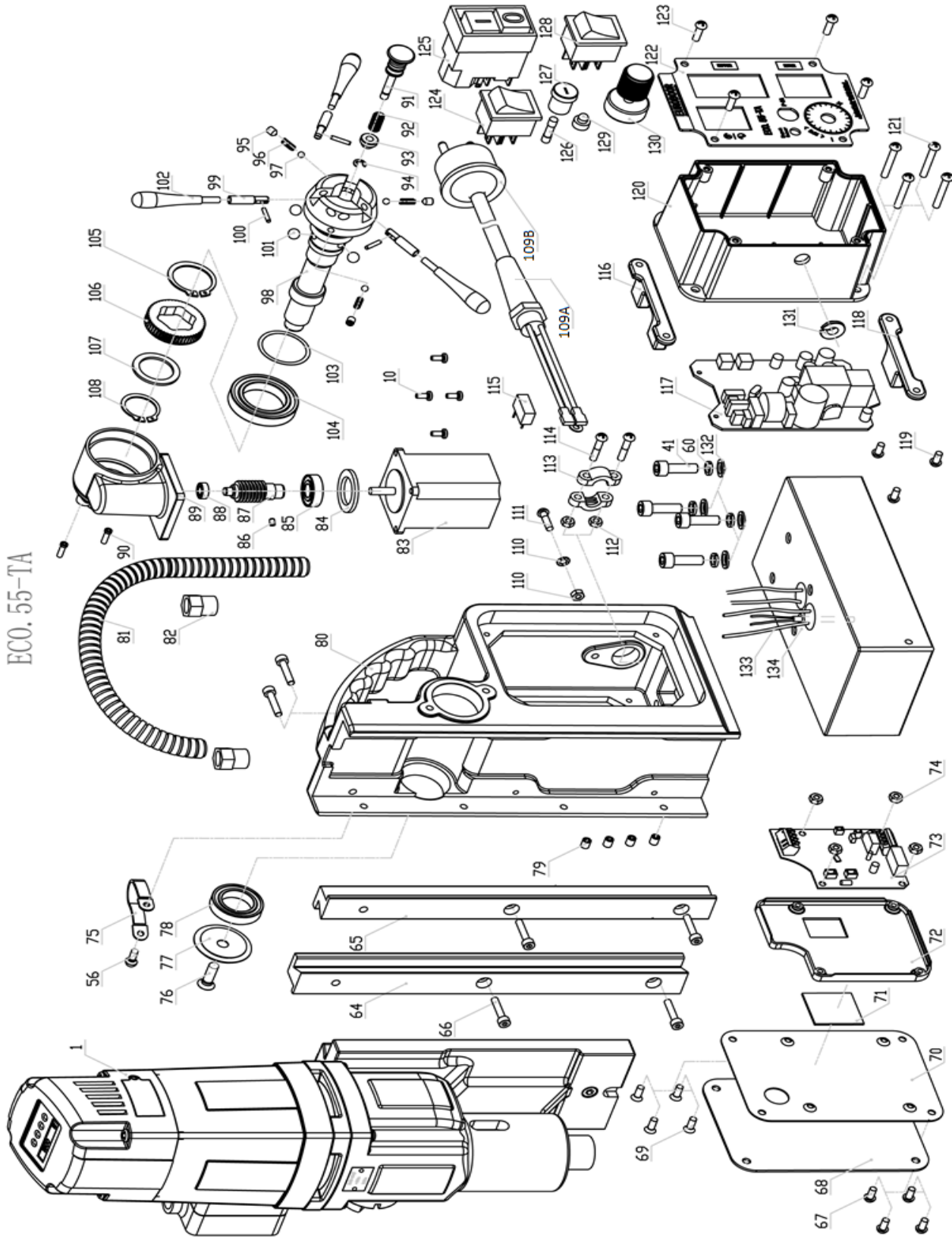

ECO. 55-TA

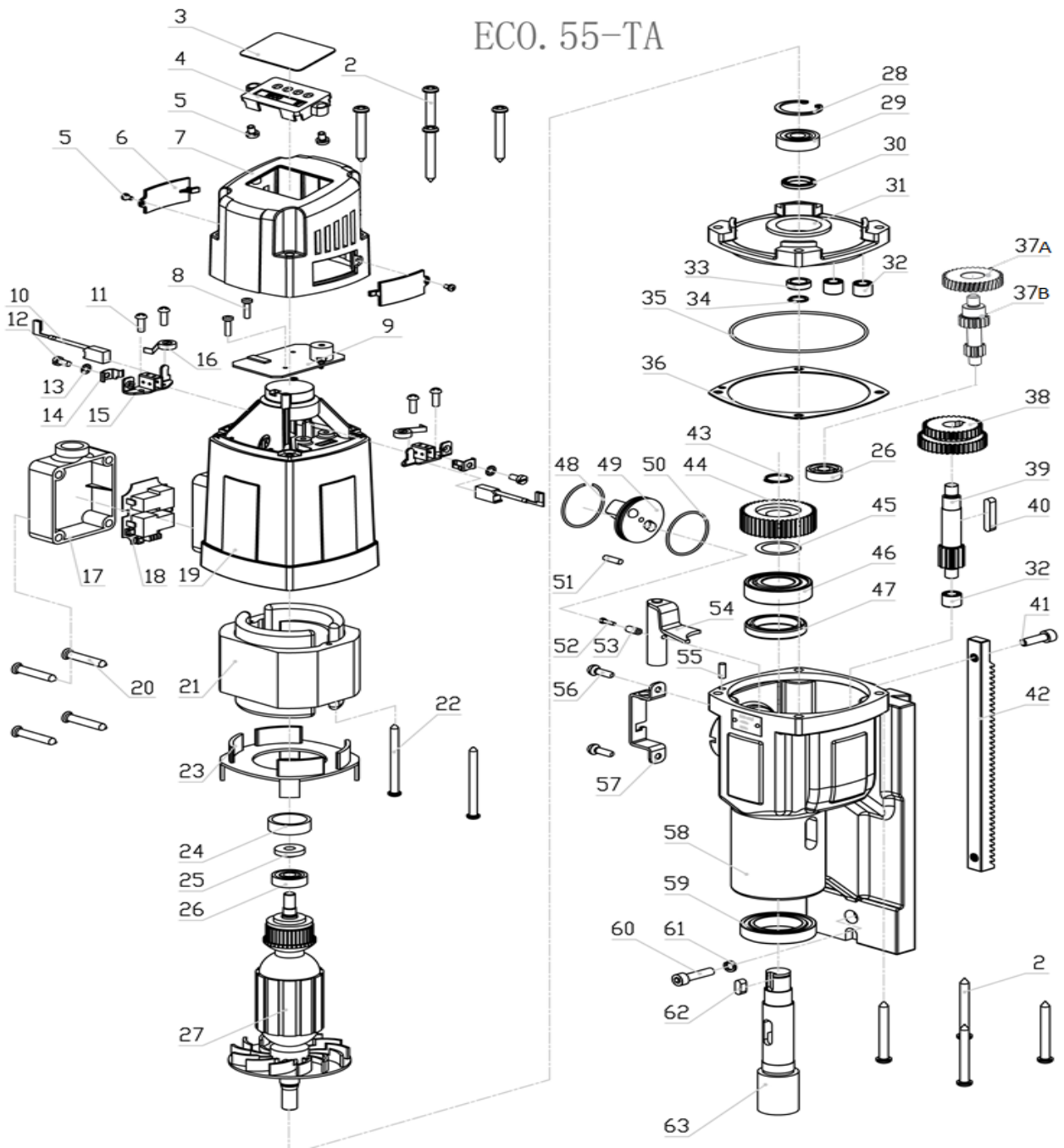

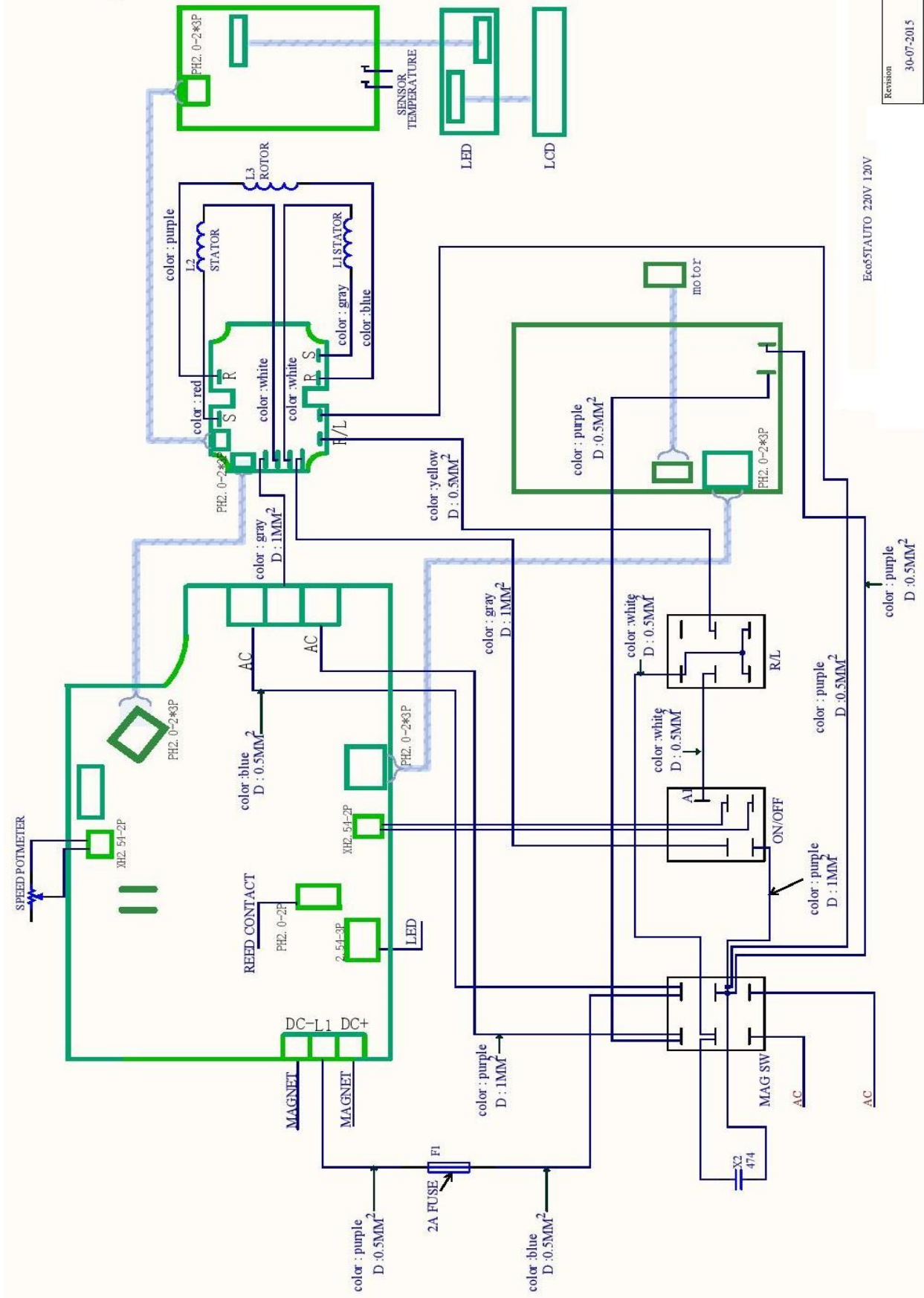

Revision
30-07-2015

ECO5TAUTO 220V 120V