

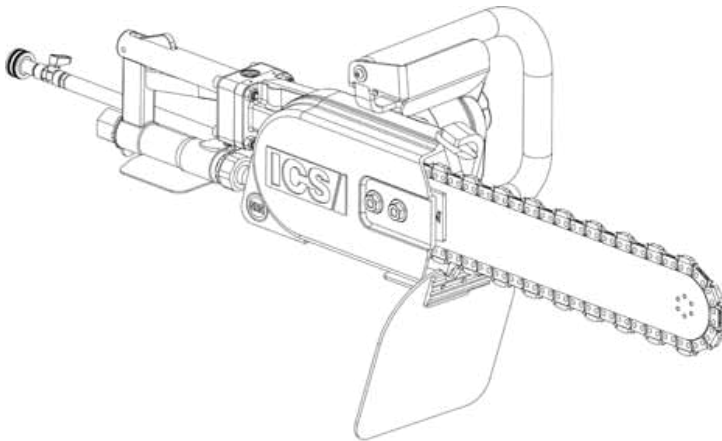

**Diamond Tools and Equipment
for Construction and Infrastructure**

AIR POWERED SAW



Model # 701A OPERATOR'S MANUAL

INTRODUCTION

This manual outlines the maintenance and operation of ICS® manufactured products.

This is a professional tool and is solely intended for use by trained and experienced operators.

The 701A Series saw is designed to cut concrete, stone, and masonry when used with the appropriate genuine ICS Diamond Chain. Other materials including ductile iron, cast iron or PVC pipe require the use of ICS PowerGrit® Utility Chain.

To get the maximum benefit from your saw, and ensure maximum safety, be sure to read this manual thoroughly, and periodically review safety instructions.

SYMBOLS & LABELS	3
SAFETY	4 - 6
TECHNICAL SPECIFICATIONS	7
SET-UP	8 - 13
OPERATION	14 - 19
TROUBLESHOOTING	20
MAINTENANCE	21 - 23
REFERENCE	24
SPARE PARTS LIST	26 - 29

SAFETY RULES

To get the maximum benefit from your saw, and ensure maximum safety, be sure to read this manual thoroughly and follow the safety instructions provided.

EXPLANATION OF WARNING LEVELS



Indicates a hazard with a high level of risk which, if not avoided, will result in death or serious injury.



Indicates a hazard with a medium level of risk which, if not avoided, could result in death or serious injury.



Indicates a hazard with a low level of risk which, if not avoided, could result in minor or moderate injury.



Indicates a potential situation exists which, if not avoided, may result in damage to your machine or property.



To get the maximum benefit from your saw and ensure maximum safety, be sure to read and understand this manual thoroughly and follow the safety instructions provided



Always use:

- Protective helmet
- Ear protection
- Protective glasses or full face protection



Wear hand protection

▲ WARNING	
	• Do not exceed 90psi (6 bar) air pressure or 124 cfm (3.5m ³ /min) air volume
	• Do NOT insert tool into slot narrower than chain.
	• Do NOT operate tool without solid footing and firm hand grip.

▲ WARNING	
• Do NOT operate saw without side cover.	• Do NOT use this saw cover on any other saw model.
• Do NOT operate saw without baffle drain.	• Failure to observe these precautions can result in serious injury.

THE FOLLOWING WARNING SYMBOL APPLIES TO ALL THE ITEMS LISTED ON THIS PAGE

Indicates a hazard with a medium level of risk which, if not avoided, could result in death or serious injury.

Note: Chain breakage can result in high-speed ejection of parts, which can result in death or serious personal injury to operators or bystanders. The items listed immediately below are critical to minimizing the risk of chain breakage and injury.

- **DO NOT operate the machine with damaged, modified or missing components shown below.**
 - Side cover
 - Mud flap
 - Rear hand guard
 - Mud flap bracket (chain catcher)
 - Trigger interlock

- **DO NOT exceed 90 psi (6 bar) and 124 cfm (3.5 m³/min) operating pressure and volume.**

- **DO NOT insert the diamond chain saw into a slot narrower than the chain segments.**

Rapid pushback might occur.
NOTE: Most ICS diamond chain segments are .225 inches (5.72 mm) wide.

- **NEVER run a diamond chain saw upside-down.**

Concrete debris can fly back into the operator's face.

- **NEVER cut ductile iron pipe with concrete chain.**

Segment loss or chain breakage may occur.

- **NEVER operate the ICS saw with a saw chain or saw bar designed to cut wood.**

Using wood cutting saw chain on the ICS saw could result in severe injuries to operator and bystanders! Use **ONLY** the cutting attachments specified in this manual on this machine.

THE FOLLOWING WARNING SYMBOL APPLIES TO ALL THE ITEMS LISTED ON THIS PAGE

Indicates a hazard with a medium level of risk which, if not avoided, could result in death or serious injury.

This machine can generate hazardous dust and vapors.

Determine the nature of the material you are going to cut before proceeding with the job. Be especially aware of cutting materials containing silica and asbestos as inhaling dust can result in respiratory disease. Be sure to use appropriate respiratory protection designed to filter out microscopic particles. Be sure to use adequate water pressure.

Over-exposure to vibration can lead to circulatory and/or nerve damage to the extremities, especially in cold temperatures (Reynaud's Disease).

If you experience tingling, numbness, pain or changes in skin color, particularly in your fingers, hands or wrists, stop using the machine immediately. If the problem persists, seek medical attention.

THE FOLLOWING WARNING SYMBOL APPLIES TO ALL THE ITEMS LISTED ON THIS PAGE

Indicates a hazard with a low level of risk which, if not avoided, could result in minor or moderate injury.

- Always disconnect the air supply and relieve pressure from supply lines before performing maintenance on the saw.
- Diamond chains and guidebar require a minimum water pressure of 20 psi (1.4 bar). Insufficient water supply may result in excessive wear to the guidebar or diamond chain, which can lead to loss of strength and diamond chain breakage and damage the bar.
- When operating a compressor with greater than 90 psi (6 bar) it is recommended to use a "service unit with pressure regulator" in line to prevent over speeding the saw.

GENERAL SAFETY PRECAUTIONS

- Always wear protective clothing, including a hard hat, eye protection, hearing protection and gloves.
- Avoid loose clothing.
- Perform safety checks before starting each day.
- Always operate tool with solid footing and handgrip.
- Remove or control slurry to prevent yourself or others from slipping while cutting.
- Always work in a cleared area.
- Be sure there are no obstructions (plumbing, electrical conduit, air ducts).
- Set up a well-marked safety zone with a roped boundary and clear signs to keep bystanders at least 20 ft (5m) away.
- Breathing exhaust fumes is dangerous. Provide ventilation in closed areas.
- To avoid electrocution, check for live electrical wiring near cutting area.

Weight without bar and chain	29 lbs (13 kg)
Length	20 in (58.5 cm)
Height	10.5 in (26.5 cm)
Width	12 in (30.5cm)
Air Motor Power	6.5 Hp (5 Kw)
Air Supply Requirements (maximum)	90psi (6 bar) 124 cfm (3.5 m ³ /min)
Motor lubrication requirements	Resin and acid-free SAE 5 W to SAE 10 W oil
Water Pressure Requirements	Minimum: 20 psi (1.4 bar)
Water Flow Requirements	1 gpm (4 lpm) minimum
Operating Speed	5,700 rpm (average free running) 4,900 sfm (average free running chain)
Vibration $a_{hv,eq}$ Concrete Cutting ⁽²⁾	Front handle: 5.09 m/s ² (K=0.2 m/s ²) Rear handle: 5.07 m/s ² (K=0.2 m/s ²)
Vibration $a_{hv,eq}$ PowerGrit Cutting ⁽²⁾	Front handle: 4.58 m/s ² (K=0.2 m/s ²) Rear handle: 4.43 m/s ² (K=0.2 m/s ²)
Guaranteed Sound Power Level L_{wa} ⁽¹⁾	113 dB(A); (K _{wa} =0.5 dB(A))

(1) Measured in accordance with ANSI S12.51-2012/ISO3741:2010

(2) Measured in accordance with ISO5349-1:2001 and ISO22867:2011

• When operating a compressor with pressure greater than 90 psi (6 bar) it is recommended to use a "service unit with pressure regulator" in the line to prevent over speeding the saw.

• Always use an in-line oiler or air pac ICS p/n 575013 to provide continuous lubrication to the air motor. This will increase the life of the saw and reduce down time.

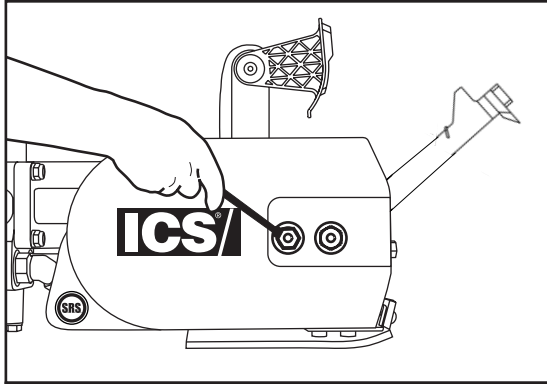
**STEP 1**

Loosen the side cover nuts and remove the side cover and bar clamp plate.

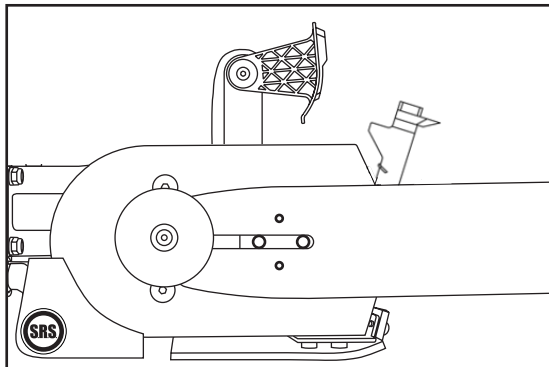
**STEP 2**

Place the bar onto the studs and the chain adjustment pin.

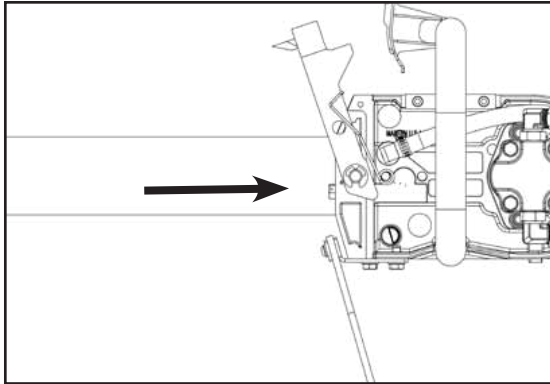
**STEP 3**

Turn the chain-tensioning screw counterclockwise until the bar comes into contact with the drive sprocket.

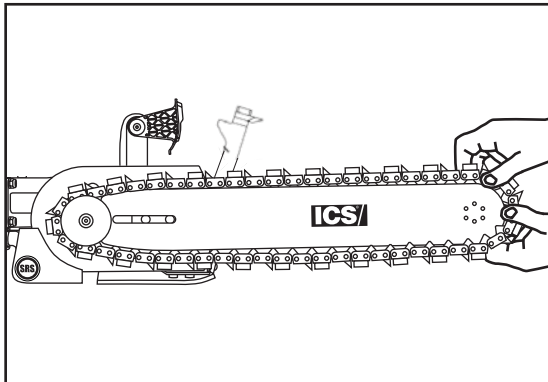
**STEP 4**

Mount the chain on the bar starting at the drive sprocket & continue over the bar nose.

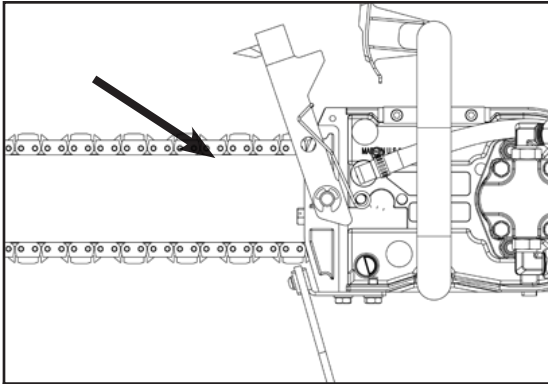

STEP 5

Make sure all of the drive links are inside the bar groove, then pre-tension the chain by turning the tensioning screw counterclockwise.

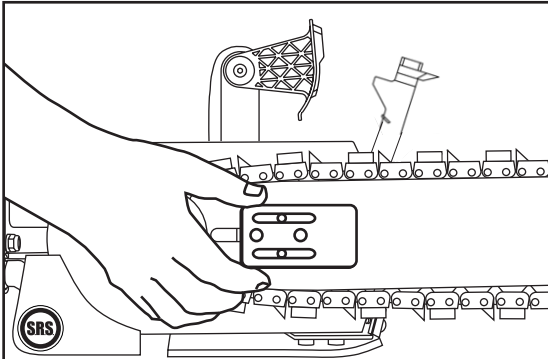

STEP 6

Install the bar clamp plate over the bar studs in proper orientation. "Front" is marked on the plate.

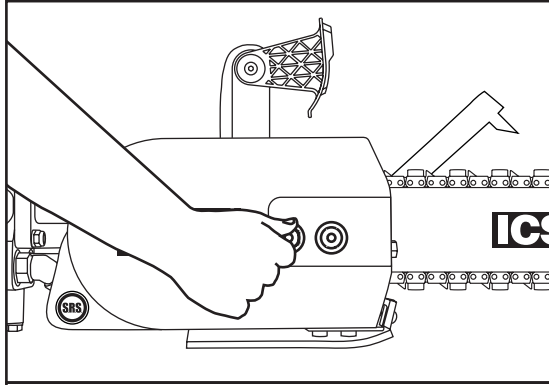
**STEP 7**

Install the side cover over the bar studs and install side cover nuts. Finger tighten only.

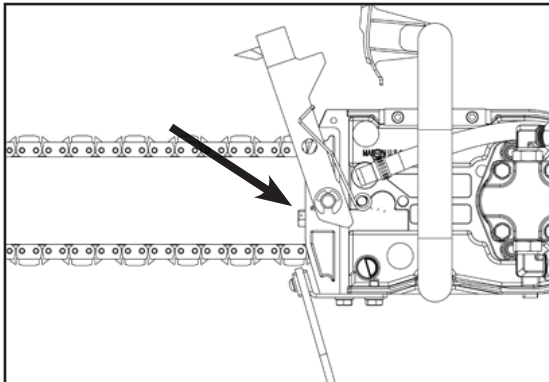
**STEP 8**

Tension the chain properly. Do not over tension the diamond chain. Loss of power will result.

! CAUTION

CORRECT CHAIN TENSION

All chains have a tendency to stretch when used. Diamond chains stretch more than wood cutting chains because of the abrasive materials they are cutting.

If the chain is too tight, more power goes into turning the chain rather than into the cut. In extreme over-tightened cases, the saw may not be able to turn the chain at all. In addition, damage can occur to the bar nose and premature stretch may occur.

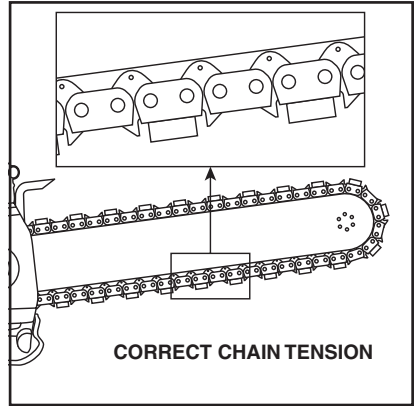

IMPORTANT

! CAUTION

CHAIN TOO LOOSE

If the chain is too loose, it could come off the bar, or it will allow the drive sprocket to spin without turning the chain, which can damage drive links.

When a chain stretches to a point where the drive links are hanging approximately 1/2 in (12 mm) to 3/4 in (18 mm) below the bar, it is time to tension the chain.

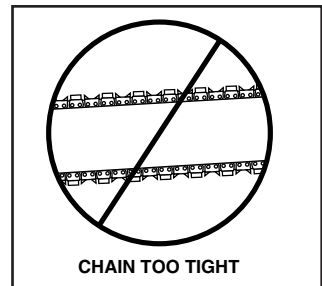
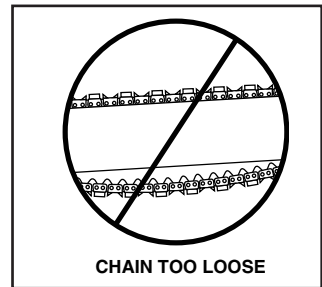

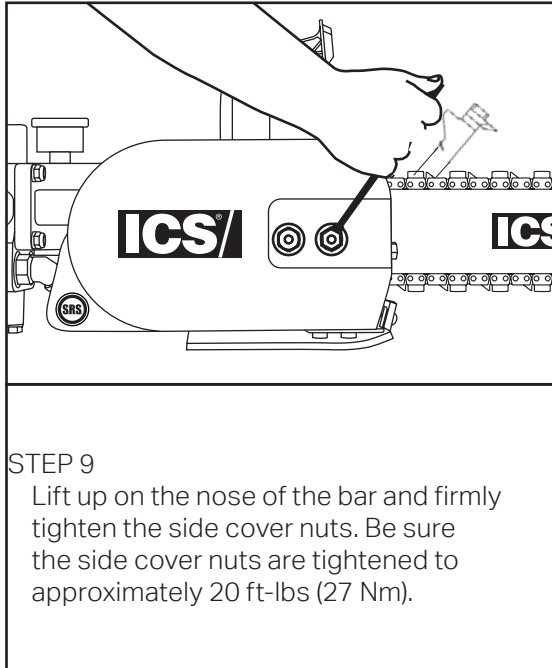

PRE-CUT CHECKLIST



To maximize the life of the cutting system, ensure that proper chain tension is maintained.

If tension is too tight, it will lead to excessive chain stretch, and a lot of the saw's power will be used to overcome friction. In severe cases the chain may not turn at all and can lead to chain breakage. If the tension is set too loose, the chain could be thrown off of the bar, or allow the sprocket to turn with out turning the chain, which will damage the drive links.

PROPER CHAIN TENSION

Concrete cutting chainsaws operate with looser chain tension than wood chainsaws. It is common, especially on gas powered, concrete cutting chainsaws to have the drive links hang completely out of the bar. Concrete cutting chainsaws require water for cooling and flushing the cut. Rotating the chain completely around the bar freely by hand will let you know you have the chain properly tensioned.

ADDITIONAL TENSIONING TIPS:

1. To reduce chain stretch and tensioning downtime, use 20 psi (1.5 bar) or greater water pressure.
2. Oil the chain at the end of the day to prevent rust but be careful not to over tension in this condition.
3. When pulling the chain around the bar by hand, be sure to wear gloves. The bar rails can be very sharp. Grab only the diamond segments to pull the chain.
4. Always pull the chain away from the WallWalker®. The point of the WallWalker can also be very sharp.



Before tensioning chain, always turn the compressor off and relieve system pressure before disconnecting from the compressor.

PRE-CUT CHECKLIST, CONT.

- Adequate Water Supply and Pressure:
Minimum Flow: 1 gpm (4 lpm)
Minimum Water Pressure: 20 psi (1.4 bar)
Checking for water pressure without a pressure gauge: With the compressor off, attach water hose to the saw water connection. Pull the chain off to one side of the bar and turn on the water valve. If there is a minimum of 20 psi, water should spray 1 - 3 ft (.5 to 1 m) from the bar.
- Proper Air Supply to the Saw:
Maximum PSI: 90 (6 bar)
Maximum CFM: 124 cfm (3.5 M³/min)
Insure the air supply line is clear before connecting it to the saw. Dirt and water separators are recommended to prevent rust and condensation from forming in the air lines.
- Motor Lubricator: (Not Included)
Always use an in-line oiler to provide continuous lubrication to the air motor. This will increase the life of the saw and reduce down time.
Check oil level, when necessary; fill with resin and acid-free SAE 5 W to SAE 10 W oil.

In winter or when using very moist air, use antifreeze lubricant, such as "ICS Prolube ATL/AF", "Killfrost" "BP Energol AX10" or "Kompranol"

 **WARNING**

If cutting pipe with PowerGrit® be sure the cut line stays open by providing proper pipe support. Also check for neighboring utilities or obstructions.

Concrete is very heavy, 1 cubic foot (30 cubic cm) weighs 150 lbs (68 kg). Be sure to cut so that concrete cannot fall and injure operator or bystanders.

Check for live electrical wiring near the cutting area or in the concrete to avoid electrocution which can result in death or serious personal injury.

PLANNING THE CUT

- Select the proper chain for the material being cut.
- Outline the cut with a permanent marker for a visual cutting guide.
- Avoid pinching the bar and chain. Always cut the bottom of an opening first, then top, and then the sides. Save the easiest cut for last.

 **CAUTION**

Wear gloves when handling the bar and chain. Over time, these components can develop sharp edges and cause cuts.

- When cutting reinforced concrete, be sure you are always cutting concrete as well as rebar. This will prevent the segments from glazing over and keep the diamonds exposed. Also, expect less chain life when cutting concrete with heavy rebar.
- When replacing a chain, flip the guidebar over and dress your guidebar rails to maintain straight cuts. Guidebar rails can be dressed with a flat file or belt sander.
- Note: The normal life of a guidebar is 2 to 3 chains. However, heavy rebar can shorten guidebar life too.
- When using a new chain, cutting speed can be increased by "opening up the diamonds". Make a few plunge cuts in an abrasive material such as a cinder block.

OPERATING THE DIAMOND CHAINSAW IN CONCRETE

- When cutting into concrete, plunge cut instead of starting at the top of the wall. This will reduce chatter, extend diamond life, create a straighter cut and more quickly enable the use of the Wallwalker®.
- Always operate a diamond saw at full throttle. If too much force is applied, the saw will lug or stall and the chain will not have enough speed to cut effectively. If too little force is applied, the diamonds will skid and glaze over.
- For the straightest cuts use the "step cut" method. First score the entire cut line with the nose of the bar approximately ½ inch (12 mm) to 1 inch (25 mm) deep. Next, deepen the cut by about 2 inches (50 mm). This groove will help guide the bar for a straight cut. Then plunge all the way through and complete the cut using the Wallwalker®.
- Use the Wallwalker to cut efficiently and reduce operator fatigue. The Wallwalker when extended is a fulcrum that converts inward force to downward force and will develop a 4-to-1 mechanical advantage. To use correctly, plunge into the wall and simply engage the point of the Wallwalker into the cut and push straight in. The Wallwalker will force the saw to feed down.

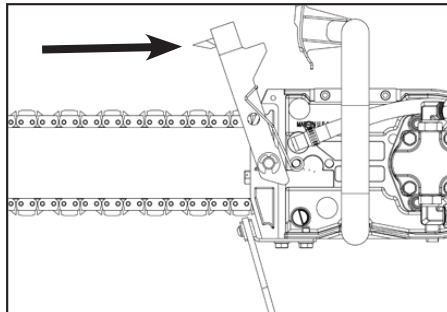

SYSTEM CLEAN-UP

1. Run saw, with water on, for 15 seconds out of cut to flush slurry and debris from chain, bar and drive sprocket.
2. Wash concrete slurry from saw body.
3. Remove bar and chain. Flush out chain tensioner assembly location with high water pressure and lube with grease.
4. Clean all air fittings on saw and compressor.
5. When done cleaning saw, spray entire saw body, chain, bar, and drive sprocket with a lightweight penetrating oil. This will minimize rust and reduce slurry build up on saw assembly.

- **SLOW CHAIN SPEED** - Be sure the compressor is providing the correct air pressure at the saw (90 psi = 6 bar) and cubic feet per minute (124 cfm = 3.5 m³/min)
- **POOR CUTTING PERFORMANCE** - Diamonds may be "glazed over". Make a few plunge cuts in an abrasive material such as a cinder block to expose the diamonds.

NOTE: This does not apply to PowerGrit® chains.

- **PREMATURE CHAIN STRETCH** - Not enough water pressure, the minimum water pressure is 20 psi (1.4 bar). Insufficient water supply will result in excessive wear on the chain, which can lead to loss of strength and chain breakage. Cutting with the guidebar nose buried in the cut, in sand, gravel, pipe or using with improper chain tension will all contribute to increased chain stretch.

NOTE: This applies to PowerGrit chains also.

- **CHAIN TENSIONER BREAKAGE** - Side cover nuts are not tight enough, or tensioning was attempted with side cover nuts already fully tightened.
- **WATER NOT FLOWING** - Water hose is kinked, blockage in guidebar water ports, or supply is not turned on.
- **MOTOR DOES NOT START**
 - Insufficient air supply. Check compressor and air hose, valves, and air inlet screen for blockage.
 - Chain tension is too tight, loosen chain tension.
 - Iced exhaust. wait until ice thaws, then use anti-freeze lubricant
 - Vanes sticky. Apply lubricant directly to saw air inlet and blow motor clear. Repeat if necessary. See maintenance instructions

Further questions?

Call 800.321.1240 or visit our website at: icsdiamondtools.com

DRIVE SPROCKET REMOVAL AND INSTALLATION

Drive Sprocket Removal

Step 1. Prevent the sprocket from rotating by inserting screwdriver or screw driver through the holes in the sprocket and the hole in the saw body.

Step 2. Loosen the Trantorque® using a 7/8" box end (or adjustable) wrench.

NOTE: If Trantorque® is stuck, tap lightly with a hammer on nut to release debris. If that is unsuccessful, apply penetrating oil to Trantorque. Next, slide two (2) wedges, under the sprocket, one on each side of sprocket and alternately tap the wedges equally until trantorque and sprocket loosen or come free from shaft.

Still have questions? Please contact Technical Services: 800.321.1240

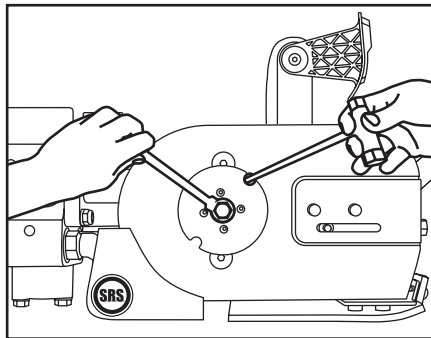

DRIVE SPROCKET INSTALLATION

Step 1. Slide Trantorque® shaft adapter onto drive shaft until it bottoms out on the end of the shaft.

NOTE: Do not lubricate Trantorque® or shaft as slippage may occur.

Step 2. Slide drive sprocket onto the Trantorque® until it bottoms on the Trantorque®

Step 3. Finger tighten Trantorque® shaft adapter.

Step 4. Stop the sprocket from rotating by inserting srench or screw driver though the holes in the sprocket and the hole in the saw body.

Step 5. Tighten the Trantorque® shaft adapter with a torque wrench and a 7/8" socket to 200 in-lbs (22.6 Nm). When a torque wrench is not available, use a 7/8" box end wrench and tighten one half turn past finger tight.

NOTE: Do not turn around or reverse the direction of the drive sprocket to extend sprocket tooth life. Damage to chain or drive links may occur.

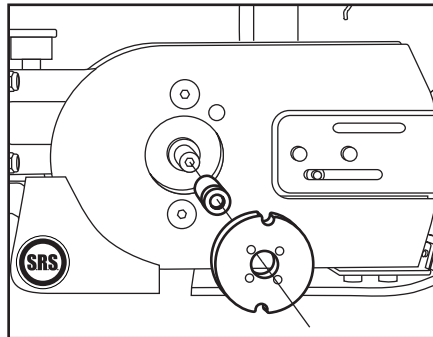

AIR MOTOR MAINTENANCE

Service life and performance of the chain saw are determined by:

1. Degree of air purity
2. Lubrication
3. Maintenance

Prior to operating the saw be sure to:

1. Blow the air hose clear prior to connecting it to the saw. Install dirt and water separators upstream of the saw.
2. Install an air lubricator upstream of the saw and fill it with SAE 5 W to SAE 10 W oil. Optimum lubrication significantly prolongs service life.
3. Regularly check and clean the air inlet screen.
4. Replace wear parts - in particular the motor vanes. It is suggested to replace the motor vanes if their width is less than 1.083 in. (27.5 mm).
5. Check oil level, when necessary; fill with resin and acid-free SAE 5 W to SAE 10 W oil.
6. In winter or when using very moist air, use antifreeze lubricant, such as: "ICS Prolube ATL/AF", "Killfrost" "BP Energol AX10" or "Kompranol.
7. Air lubricator (oiler) can be adjusted to maximize atomization and minimize excessive oil use.

KEEP TOOL CLEAN

APPROXIMATE CUTTING RATES

Material	Cutting Rate
Concrete – 6 in (15 cm)	5 lineal in/min (12 cm/min)
Red Brick – 6 in (15 cm)	10 lineal in/min (25 cm/min)
Rebar – #4 (12 mm)	10–20 seconds through each piece
*Rebar must be encased in concrete, never cut bare rebar with ICS Diamond Chain.	

INCH-FOOT DEFINITION

An in-ft is a measure of how much material is to be cut.
An in-ft is defined as: depth in inches times length in feet.

Note: $129 \text{ in-ft} = 1 \text{ m}^2$

Example: How many in-ft are in this doorway?

1. Determine the depth of the cut in inches.
For this example, 8 inches.
2. Determine the length of the cut in feet.
 $3+7+3=20$ feet
3. Multiply the two numbers
 $8 \text{ in} \times 20 \text{ ft} = 160 \text{ in-ft}$

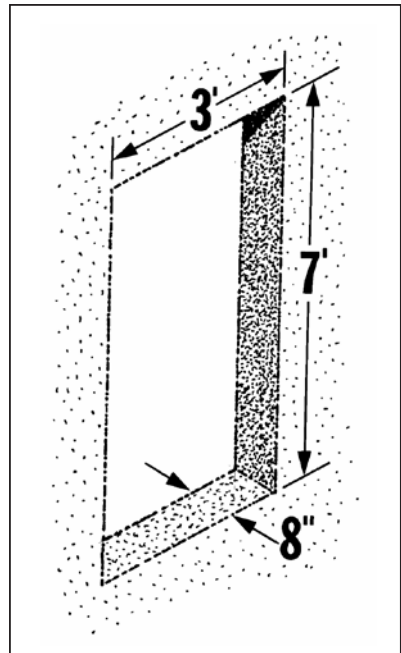

THIS PAGE INTENTIONALLY LEFT BLANK

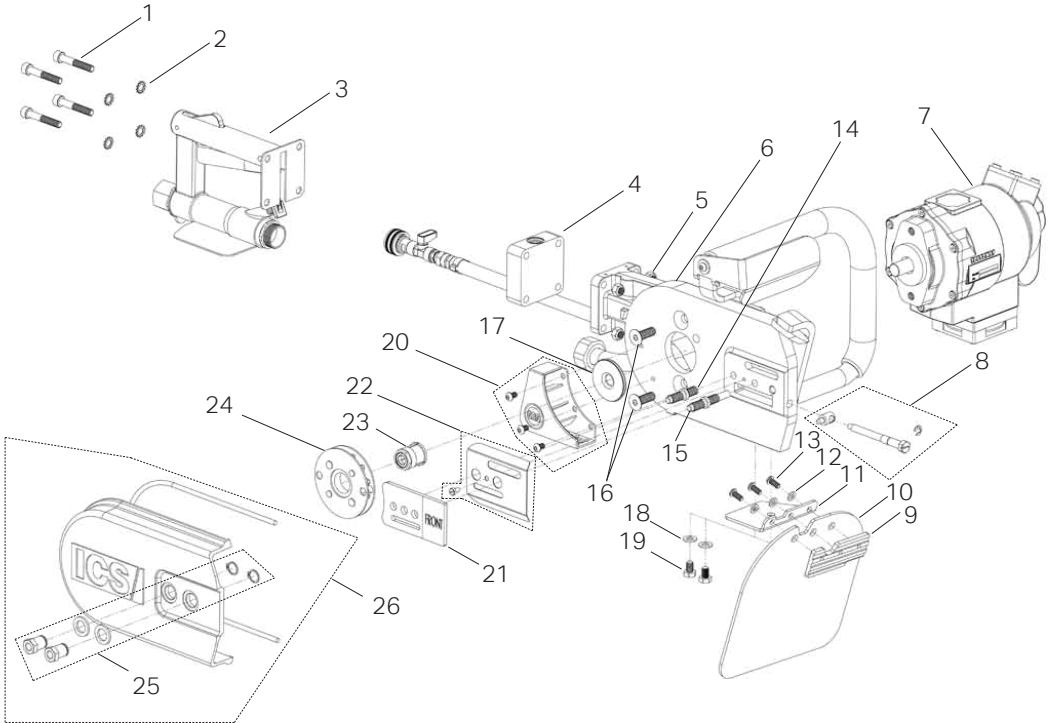

Key #	Part No.	Description
1	576557	Rear Handle Screw
2	576558	Rear Handle Washer
3	576467	Rear Handle
4	576559	Level Block
5	70135	Rear Handle Nylock Nut
6	574206	Mainframe
7	576468	Motor
8	70636	Tensioner Kit
9	574289	Mud Flap Bumper
10	574287	Mud Flap
11	574288	Mud Flap Bracket
12	530003	Washer, Black M6
13	530001	Screw, Button Head Socket Cap, M6 x 14
14	71030	Bar Mounting Stud - Short
15	71011	Bar Mounting Stud - Long
16	576573	Bolt, Motor Mount
17	525598	External Shaft Seal
18	71050	Washer M8 Plated (set of 2)
19	72414	M8 x 12mm Hex Head Bolt (set of 2)
20	512592	Baffle Drain Replacement Kit
21	71871	Bar Retainer Plate
22	70627	Bar Mount Cover Plate Kit
23	70618	Trantorque Adaptor 9/16
24	525495	Drive Sprocket FORCE4-12T
25	70639	Retaining Nut Kit (set of 2)
26	528564	Side Cover Replacement Kit (incl Key # 25)

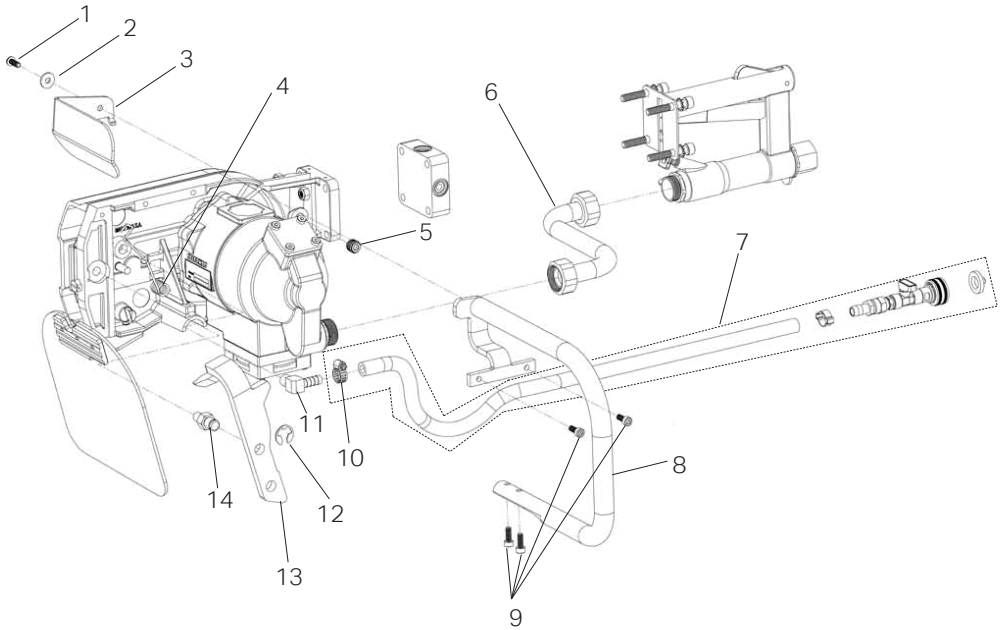

Key #	Part No.	Description
1	71005	Screw M6 x 16 BSHCS Plated
2	71004	Washer M6 Plated
3	570939	Front Handle Guard
4	70976	Torsion Spring, WallWalker®
5	504766	1/4" NPT Hex Plug, S.S.
6	576466	Connection Tube (fitting included)
7	576527	Water Shut-Off Sub Assy, 2 ft.
8	576325	Front Handle Assembly
9	71097	Screw M6 x 16 SHCS plated (set of 4?)
10	71133	Screw Hose Clamp
11	71065	90 degree water fitting
12	71896	WallWalker® Stud C-Clip
13	70873	Lever Arm
14	70874	Pro Pivot Stud

THIS PAGE INTENTIONALLY LEFT BLANK

THIS PAGE INTENTIONALLY LEFT BLANK

**ICS, Blount Inc.
4909 SE International Way
Portland, OR 97222
Tel 800.321.1240 Fax 503.653.4393
icsdiamondtools.com**